

Request drawing

Please enter desired dimensions in fields:

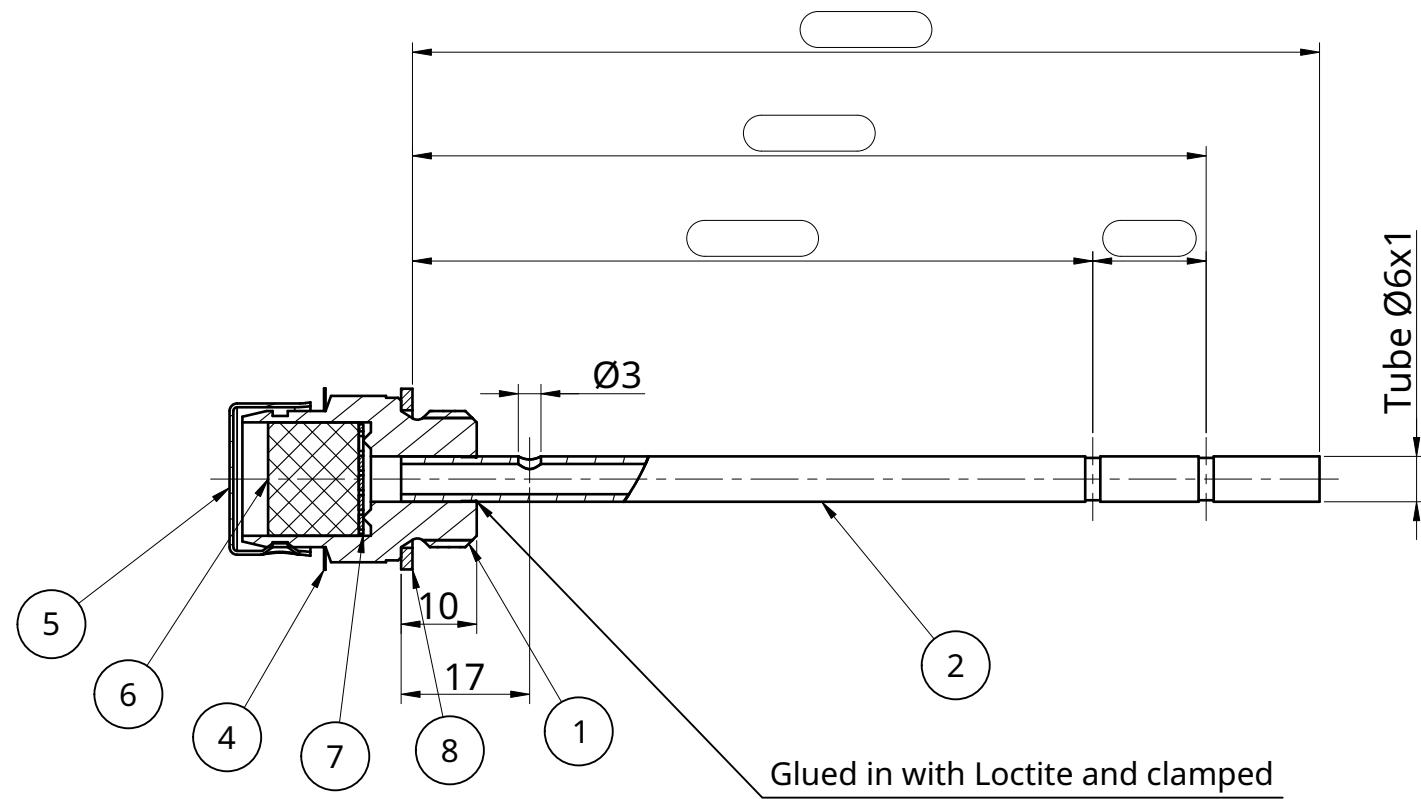
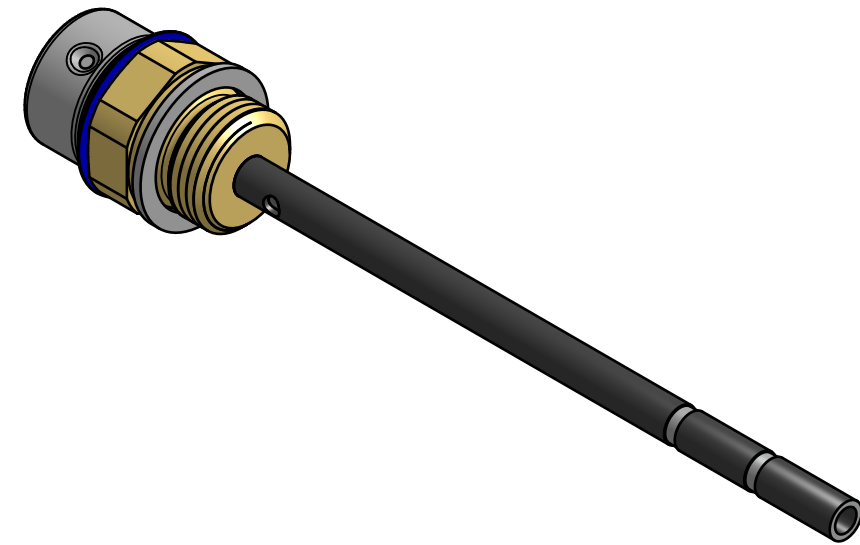
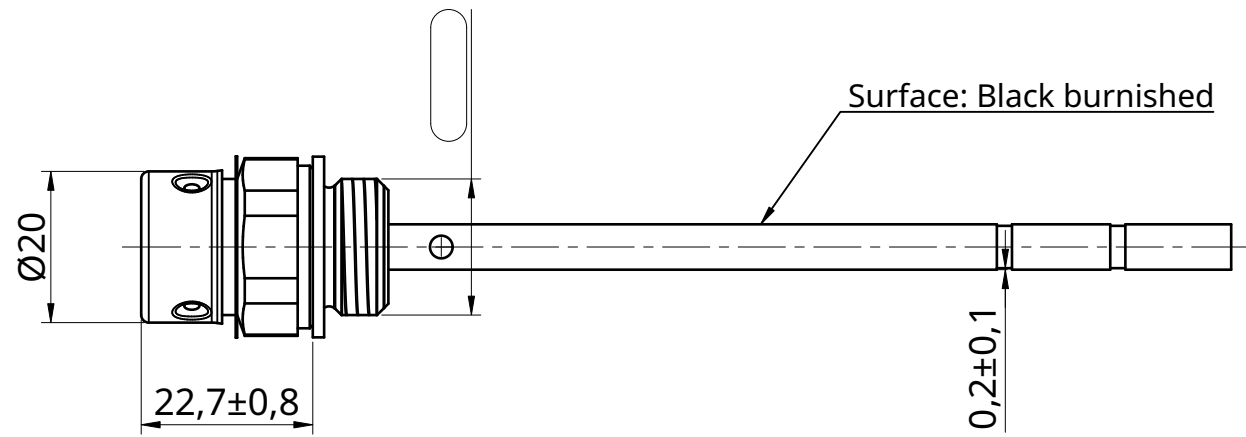

Pos. / Item	Anz. / Qty.	Description	Material	Surface
1	1	Body EV+BE	2.0401 CuZn39Pb3	bare
2	1	Measuring rod tube	E235+N	burnished black
3	2	loctite Art.-Nr. 19150	Loctite 2701	green
4	1	identification ring blue 18,2 x 24 x 0,2	PVC blue	blue
5	1	ventilation cap EV+BE 1.4301	1.4301 X5CrNi10-10 A2	bare
6	1	Wire mesh pellet 15x12	1.4301 wire 0,25mm	bare
7	1	perforated plate 14,5	1.4301 X5CrNi10-10 A2	bare
8	1	VA 1.4571 Sealing ring DIN 7603 - A	1.4571 X6CrNiMoTi17-12-2 A4	bare

		Mass: 0.0000 kg	Scale: 1:1	Pos:	Quantity:
		State: CAD ±10%	Separate BOM	Separate BOM	
Dimensions without tolerance indication DIN ISO 2768-mk	Drawn	Date: 02.03.2023	Name: Glanzner	Oil measurement tube with air vent filter	
Maße ISO 14405-1 / Size ISO 14405-1	Checked	Date: 02.03.2023	Name: Schmitt		
Surfaces, series 2 by DIN ISO 1302	Norm			Skarke GmbH Auf der Rut 4 / 64668 Rimbach-Mitlechtern Phone: 06253/8062-0 Fax: 06253/8062-22	
Edges by DIN ISO 13715					
Copyright protection! We reserve all rights for this technical file.			(State of the drawing: IN PROGRESS)		

Drawing: Oil measurement tube with air vent filter

(State of the drawing: IN PROGRESS)